

RESOLUTION MEPC.205(62)

Adopted on 15 July 2011

2011 GUIDELINES AND SPECIFICATIONS FOR ADD-ON EQUIPMENT FOR UPGRADING RESOLUTION
MEPC.60(33)-COMPLIANT OIL FILTERING EQUIPMENT

ANNEX 24

RESOLUTION MEPC.205(62)

Adopted on 15 July 2011

**2011 GUIDELINES AND SPECIFICATIONS FOR ADD-ON EQUIPMENT FOR UPGRADING
RESOLUTION MEPC.60(33)-COMPLIANT OIL FILTERING EQUIPMENT**

THE MARINE ENVIRONMENT PROTECTION COMMITTEE,

RECALLING Article 38(a) of the Convention on the International Maritime Organization concerning the functions of the Committee,

NOTING resolution MEPC.107(49), adopted on 18 July 2003, by which the Marine Environment Protection Committee adopted, at its forty-ninth session, the current revised Guidelines and Specifications for Pollution Prevention Equipment for Machinery Space Bilges of Ships and invited Governments to adopt and apply them to the maximum possible extent which they found reasonable and practicable and to report to the Organization the results of such application,

NOTING FURTHER the provisions of regulation 14.6 of Annex I of the International Convention for the Prevention of Pollution from Ships, 1973, as modified by the Protocol of 1978 relating thereto (MARPOL), in which reference is made to the above-mentioned revised Guidelines and Specifications,

HAVING CONSIDERED, at its sixty-second session, the Guidelines and Specifications for add-on equipment for upgrading resolution MEPC.60(33)-compliant oil filtering equipment, developed by the Sub-Committee on Ship Design and Equipment,

1. ADOPTS the 2011 Guidelines and Specifications for add-on equipment for upgrading resolution MEPC.60(33)-compliant oil filtering equipment, the text of which is set out in the annex to this resolution;
2. INVITES Governments to:
 - (a) consider the Guidelines and Specifications and encourage their application so that add-on equipment voluntarily installed on board ships to upgrade existing oil filtering equipment compliant with the provisions of the revised Guidelines and Specifications for Pollution Prevention Equipment for Machinery Space Bilges of Ships adopted by resolution MEPC.60(33) meets these Guidelines and Specifications for add-on equipment; and
 - (b) provide the Organization with information on experience gained from their application and, in particular, on successful testing of equipment against the Specifications;
3. REQUESTS the Secretariat, on the basis of information received, to maintain and update a list of approved equipment and to make it available through the Global Integrated Shipping Information System (GISIS);
4. FURTHER INVITES Governments to issue an appropriate "Certificate of type approval" as referred to in paragraph 4.2.1 of the Specifications and to recognize such certificates issued under the authority of other Governments as having the same validity as certificates issued by them.

ANNEX

**2011 GUIDELINES AND SPECIFICATIONS FOR ADD-ON EQUIPMENT
FOR UP-GRADING RESOLUTION MEPC.60(33)-COMPLIANT
OIL FILTERING EQUIPMENT**

TABLE OF CONTENTS

1	INTRODUCTION
1.1	General
1.2	Scope
1.3	Up-grading options
2	DEFINITIONS
3	TECHNICAL SPECIFICATIONS
4	SPECIFICATION FOR TYPE APPROVAL TESTING OF ADD-ON EQUIPMENT
4.1	Testing requirements
4.2	Approval and certification procedures
5	INSTALLATION REQUIREMENTS
ANNEX	– TEST AND PERFORMANCE SPECIFICATIONS FOR TYPE APPROVAL OF ADD-ON EQUIPMENT FOR UPGRADING RESOLUTION MEPC.60(33)-COMPLIANT OIL FILTERING EQUIPMENT
PART 1	– ADD-ON EQUIPMENT TO BE FITTED TO SPECIFIC OIL FILTERING EQUIPMENT APPROVED UNDER RESOLUTION MEPC.60(33)
PART 2	– ADD-ON EQUIPMENT TO BE FITTED TO ANY OIL FILTERING EQUIPMENT
PART 3	– DOCUMENTATION OF APPROVAL
Appendix 1	– Certificate of type approval for add-on equipment
Appendix 2	– Test data and results of tests conducted on add-on equipment in accordance with Part 1 or 2 of the annex to the 2011 Guidelines contained in resolution MEPC.205(62)

1 INTRODUCTION

1.1 General

1.1.1 In 2003, the Marine Environment Protection Committee adopted the Revised guidelines and specifications for pollution prevention equipment for machinery space bilges of ships (resolution MEPC.107(49)). The main purpose of this revision of the specifications of oil filtering equipment was to improve their capability of treating emulsified oil.

1.1.2 The present Guidelines have been developed to provide further assistance for upgrading systems installed on board ships prior to 1 January 2005, and of which oil filtering equipment was approved under resolution MEPC.60(33).

1.1.3 It has been recognized that the best measure to prevent pollution resulting from oily bilge water is installation of Integrated Bilge Water Treatment System (IBTS) in accordance with MEPC.1/Circ.642 as may be amended. IBTS prevents generation of oily bilge water. Although it may not be easy or practicable to fit complete IBTS on existing ships, pre-cleaning of oily bilge water, e.g., provision of a primary tank between bilge wells and bilge tank, should be seriously considered in order to remove impurities in bilge through surfacing or sedimentation, which is an effective way of preventing clogging of bilge separators.

1.2 Scope

These guidelines apply to add-on post-treatment equipment for resolution MEPC.60(33)-compliant oil filtering equipment in order to improve their capabilities of treating emulsified oil so that emulsion-breaking performance of oily bilge separators to be achieved by installation of add-on equipment could be equivalent to that of resolution MEPC.107(49)-compliant equipment.

1.3 Up-grading options

Equipment for upgrading existing oil filtering equipment are the following two types:

- .1 equipment which could upgrade specific make of oil filtering equipment. Such equipment should be tested in accordance with Part 1 of the test specifications contained in the annex hereto, connected to a resolution MEPC.60(33) oil filtering equipment and type approved for use in conjunction with that specific make of oil filtering equipment tested, subject to: 1) environmental testing contained in Part 3 of the annex to resolution MEPC.107(49) and 2) the limiting conditions of the certification of the upgraded equipment.
- .2 equipment which could upgrade any make of resolution MEPC.60(33)-compliant oil filtering equipment. Such equipment should be tested in accordance with Part 2 of the test specifications contained in the annex hereto and type approved for use in conjunction with any make of oil filtering equipment, subject to: 1) environmental testing contained in Part 3 of the annex to resolution MEPC.107(49) and 2) the limiting conditions of the certification of the upgraded equipment.

2 DEFINITIONS

Unless otherwise specified, definitions of the terms used in the Revised guidelines and specifications for pollution prevention equipment for machinery space bilges of ships (resolution MEPC.107(49)) apply to these Guidelines.

3 TECHNICAL SPECIFICATIONS

3.1 The add-on equipment should be strongly constructed and suitable for shipboard use, bearing in mind its intended location on the ship.

3.2 It should, if intended to be fitted in locations where flammable atmospheres may be present, comply with the relevant safety regulations for such spaces. Any electrical equipment which forms part of the add-on equipment should be based in a non-hazardous area, or should be certified by the Administration as safe for use in a hazardous area. Any moving parts which are fitted in hazardous areas should be arranged so as to avoid the formation of static electricity.

3.3 The add-on equipment should be so designed that it functions automatically in conjunction with the existing equipment.

3.4 The add-on equipment should require the minimum of attention to bring it into operation. In the case of equipment used for engine room bilges, there should be no need for any adjustment to valves and other equipment to bring the add-on equipment into operation. The equipment should be capable of operating for at least 24 hours of normal duty without attention.

3.5 It should be understood that the complete type approval with the test fluid C should be performed without interruption to attend, clean or maintain the bilge water separator. This test would be regarded as a simulation of the 24 hours of unattended operation not requiring any crew attention.

3.6 It should be understood that the 15 ppm bilge separator should operate continuously and automatically without any interruptions. It should be assured that back flushing if performed during the certification test does not cause:

- .1 dilution of the test fluid C, or
- .2 dilution of the test sample sent to the laboratory for analysis.

3.7 If input flow of test fluid C is interrupted during the performance of the test it should be assured that the total quantities of test fluid C processed automatically are not less than the nominal flow of the tested equipment multiplied by the specified test duration of 150 minutes (2.5 hours). While all the time, the tested equipment operates continuously and automatically without human intervention.

3.8 The continuous and automatic operation should apply to the performance tests with the test fluid C according to the test result diagrams in the appendix to appendix 1 of resolution MEPC.107(49) as it relates to test fluid C. However, if due to the separation process any interruption in feeding the test fluid with nominal flow rate, e.g., for back flushing, is deemed necessary, the time for these interruptions should be added to the required time of the test step which was interrupted during the performance test. While all the time, the tested equipment operates continuously and automatically without human intervention.

3.9 All working parts of the add-on equipment which are liable to wear or to damage should be easily accessible for maintenance.

4 SPECIFICATION FOR TYPE APPROVAL TESTING OF ADD-ON EQUIPMENT

4.1 Testing requirements

4.1.1 The production model of add-on equipment, for which the approval will apply, should be identical to the equipment, type-tested in accordance with the performance and test specifications contained in part 1 or 2 of the annex to these Guidelines. The equipment should also be type-tested in accordance with the specifications for environmental testing contained in part 3 of the annex to resolution MEPC.107(49).

4.1.2 Where a range of add-on equipment of the same design, but of different capacities, requires certification in accordance with these specifications, the Administration may accept tests in two capacities within the range, in lieu of tests on every size, providing that the two tests actually performed are from the lowest quarter and highest quarter of the range.

4.2 Approval and certification procedures

Add-on equipment which in every respect fulfils the provisions of these Guidelines may be approved by the Administration for fitting on board ships. The approval should take the form of a certificate of type approval specifying the main particulars of the apparatus and any limiting conditions on its usage necessary to ensure its proper performance. Such certificate should be issued in the format shown in part 3 of the annex.

5 INSTALLATION REQUIREMENTS

5.1 Before installation of add-on equipment, it is important to ascertain that the existing oil filtering equipment is well maintained and in good working condition and that the rated capacity match that of add-on equipment.

5.2 The add-on equipment should be installed between the existing oil filtering equipment and the sampling point provided for inspection purposes on board ship.

5.3 The add-on equipment should be fitted with a permanently attached plate giving any operational or installation limits considered necessary by the manufacturer or by the Administration.

5.4 A vessel fitted with an add-on equipment should, at all times, have on board a copy of the operating and maintenance manuals.

5.5 For inspection purposes on board ship, a sampling point should be provided in a vertical section of the water effluent piping as close as is practicable to the 15 ppm bilge separator and add-on equipment outlet. Re-circulating facilities should be provided, after and adjacent to the overboard outlet of the stopping device to enable the 15 ppm bilge separator system, including the 15 ppm bilge alarm and the automatic stopping device where fitted, to be tested with the overboard discharge closed.

5.6 Where fitted, the bilge alarm should be approved according to resolution MEPC.107(49).

ANNEX

**TEST AND PERFORMANCE SPECIFICATIONS FOR TYPE APPROVAL OF
ADD-ON EQUIPMENT FOR UPGRADING RESOLUTION MEPC.60(33)-COMPLIANT
OIL FILTERING EQUIPMENT****PART 1****ADD-ON EQUIPMENT TO BE FITTED TO SPECIFIC OIL FILTERING EQUIPMENT
APPROVED UNDER RESOLUTION MEPC.60(33)****1 General**

1.1 These test and performance specifications for type approval relate to add-on equipment for oil filtering equipment type approved in accordance with resolution MEPC.60(33) (hereinafter referred to as "oil filtering equipment"). In addition, the electrical and electronic systems of the add-on equipment should be tested in accordance with the specifications for environmental testing contained in part 3 of resolution MEPC.107(49).

1.2 The test of add-on equipment should be carried out in combination with oil filtering equipment to which add-on equipment being tested is intended to be added on.

2 Test specifications

2.1 These specifications relate to add-on equipment for oil filtering equipment. A set of oil filtering equipment and add-on equipment should be capable of producing an effluent for discharge to the sea containing not more than 15 ppm of oil, when 3,000 ppm oil in water emulsions are fed.

2.2 The test rig must be so constructed as to include not only oil filtering equipment and add-on equipment, but also the pumps, valves, pipes and fittings as shown in figure 1:

- .1 for the testing of oil filtering equipment having no integral pump, the centrifugal pump "A" (figure 1) is used to feed oil filtering equipment with valves 2 and 4 open, and valve 3 closed. The rate of flow from the centrifugal pump "A" is matched to the design throughput of oil filtering equipment by adjustment of the centrifugal pump's discharge valve;
- .2 a centrifugal pump "B" should be fitted to re-circulate the test fluid "C" in the tank to ensure that the test fluid "C" is maintained in a stable condition throughout the testing;
- .3 to ensure a good mix of the test fluid and the water, a conditioning pipe as specified in paragraph 2.4 should be fitted immediately before oil filtering equipment;
- .4 other valves, flow meters and sample points should be fitted to the test rig as shown in figure 1; and
- .5 the pipe work should be designed for a maximum liquid velocity of 3 metres/second.

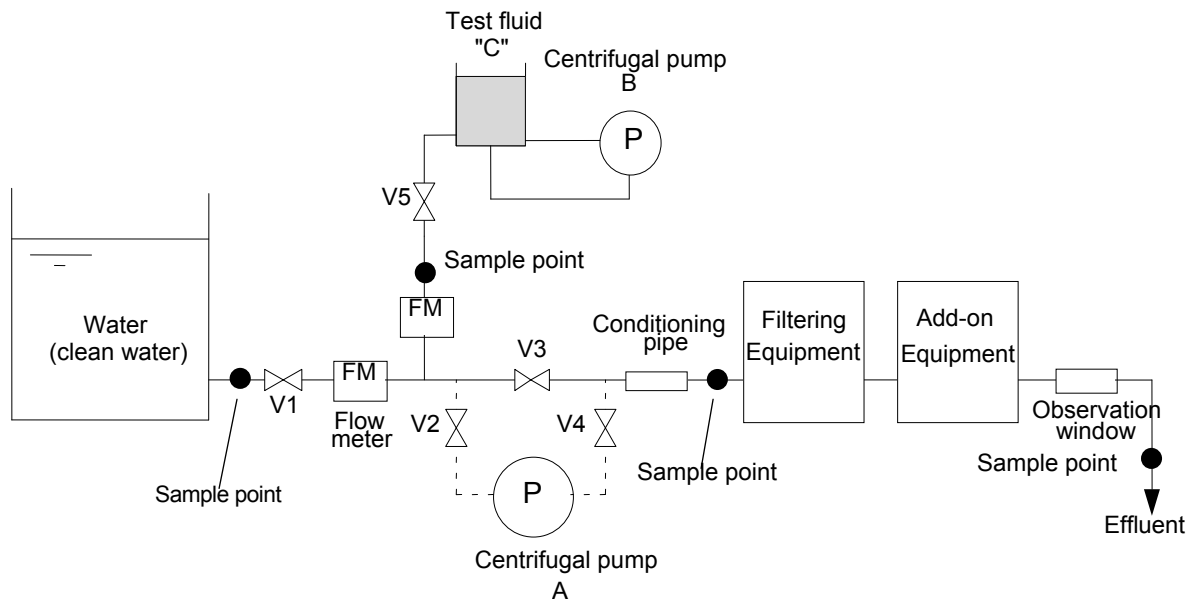

Figure 1 – Test rig

2.3 Tests should be performed using test fluid "C" as defined in resolution MEPC.107(49).

2.4 If oil filtering equipment includes an integrated feed pump, oil filtering equipment and add-on equipment should be tested with that pump supplying the required quantity of test fluid and water to oil filtering equipment at its rated capacity. If oil filtering equipment is to be fed by the ship's pumps, then the unit will be tested by supplying the required quantity of test fluid and water mixture to the inlet of a centrifugal pump operating at not less than 1,000 rpm (see dotted line in figure 1). This pump should have a delivery capacity of not less than 1.1 times the rated capacity of oil filtering equipment at the delivery pressure required for the test. If a centrifugal pump is used, the excess pump capacity should be controlled by a throttle valve on the discharge side of the pump. In all cases, to ensure uniform conditions, the piping arrangements immediately prior to oil filtering equipment should be such that the influent to oil filtering equipment should have a Reynolds number of not less than 10,000 as calculated in fresh water, a liquid velocity of not less than 1 metre per second and the length of the supply pipe from the point of test fluid injection to oil filtering equipment should have a length not less than 20 times its diameter. A mixture inlet sampling point and a thermometer pocket should be provided near oil filtering equipment inlet and an outlet sampling point and observation window should be provided on the discharge pipe.

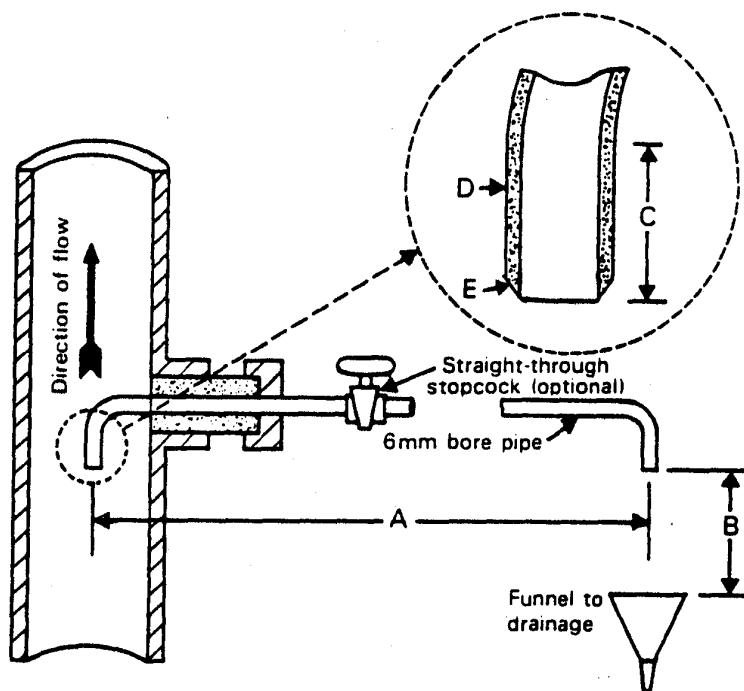

Figure 2 – Diagram of sampling arrangements

- A Distance A, not greater than 400 mm
- B Distance B, sufficient to insert sampling bottle
- C Dimension C, straight length should not be less than 60 mm
- D Dimension D, pipe thickness should not be greater than 2 mm
- E Detail E, chisel-edged chamfer (30°)

2.5 In order to approach isokinetic sampling – i.e. the sample enters the sampling pipe at stream velocity – the sampling arrangement should be as shown in figure 2 and, if a cock is fitted, free flow should be effected for at least one minute before any sample is taken. The sampling points should be in pipes running vertically.

2.6 In the case of oil filtering equipment and add-on equipment depending essentially on gravity, the feed to the system of the test water and test fluid mixture should be maintained at a temperature not greater than 40°C, and heating and cooling coils should be provided where necessary. The water shall have a density of not more than 1.015 at 20°C. In other forms of separation where the dependence of separation efficiency on temperature is not established, tests should be carried out over a range of influent temperatures representing the normal shipboard operating range of 10°C to 40°C or should be taken at a temperature in this range where the separation efficiency is known to be worst.

2.7 In those cases where, for oil filtering equipment and add-on equipment, it is necessary to heat water up to a given temperature and to supply heat to maintain that temperature, the tests should be carried out at the given temperature.

- 2.8 The tests with test fluid "C" should be carried out as follows:
- .1 prior to the test with test fluid "C", oil filtering equipment and add-on equipment should be filled up with water (density of not more than 1.015 at 20°C);
 - .2 oil filtering equipment and add-on equipment should be fed with a mixture composed of 6% test fluid "C" and 94% water to have emulsified oil content of 3,000 ppm in the test water until steady conditions have been established. Steady conditions are assumed to be the conditions established after pumping through oil filtering equipment and add-on equipment a quantity of test fluid "C"/water mixture not less than twice the volume of oil filtering and add-on equipment; and
 - .3 the test should then proceed for 2.5 h. Samples should be taken at the effluent outlet at 50 minutes and 100 minutes after conditioning. At the end of this test, an air cock should be opened on the suction side of the pump and, if necessary, the test fluid "C" and water valves should be slowly closed together, and a sample taken at the effluent discharge as the flow ceases (this point can be checked from the observation window).
- 2.9 Sampling should be carried out as shown in figure 2 so that the sample taken will suitably represent the fluid issuing from the effluent outlet of add-on equipment.
- 2.10 Samples should be taken in accordance with ISO 9377-2:2000. The sample is to be extracted on the same day of collection, and be sealed and labelled in the presence of a representative of the national authority and arrangements should be made for analysis as soon as possible and in any case within seven days, provided the samples are being kept between 2°C and 6°C at laboratories approved by the Administration.
- 2.11 The oil content of the samples should be determined in accordance with part 4 of the annex to resolution MEPC.107(49).
- 2.12 When accurate and reliable oil content meters are fitted at inlet and outlet of add-on equipment, one sample at inlet and outlet taken during each test will be considered sufficient if they verify, to within $\pm 10\%$, the meter readings noted at the same instant.

PART 2

ADD-ON EQUIPMENT TO BE FITTED TO ANY OIL FILTERING EQUIPMENT

3 General

These test and performance specifications for type approval relate to add-on equipment for any oil filtering equipment type-approved in accordance with resolution MEPC.60(33). In addition, the electrical and electronic systems of the add-on equipment should be tested in accordance with the specifications for environmental testing contained in part 3 of resolution MEPC.107(49).

4 Test specifications

4.1 These specifications relate to add-on equipment. The add-on equipment should be capable of producing an effluent for discharge to the sea containing not more than 15 ppm of oil when 3,000 ppm oil in water emulsions are fed.

4.2 The test rig must be so constructed as to include not only add-on equipment but also the pumps, valves, pipes and fittings as shown in figure 3:

- .1 for the testing centrifugal pump "A" (figure 3) is used to feed the add-on equipment. The rate of flow from the centrifugal pump "A" is matched to the design throughput of the add-on equipment by the adjustment of the centrifugal pump's discharge valve;
- .2 a centrifugal pump "B" should be fitted to re-circulate the test fluid C in the tank to ensure that the test fluid C is maintained in a stable condition throughout the testing;
- .3 to ensure a good mix of the test fluid and the water, a conditioning pipe as specified in paragraph 4.4 should be fitted immediately before add-on equipment;
- .4 other valves, flow meters and sample points should be fitted to the test rig as shown in figure 3; and
- .5 the pipe work should be designed for a maximum liquid velocity of 3 metres/second.

4.3 Tests should be performed using test fluid "C" as defined in resolution MEPC.107(49).

4.4 The add-on equipment is tested by supplying the required quantity of test fluid and water mixture to the inlet by a centrifugal pump operating at not less than 1,000 rpm. This pump should have a delivery capacity of not less than 1.1 times the rated capacity of add-on equipment at the delivery pressure required for the test. The excess pump capacity should be controlled by a throttle valve on the discharge side of the pump. In all cases, to ensure uniform conditions, the piping arrangements immediately prior to add-on equipment should be such that the influent to add-on equipment should have a Reynolds number of not less than 10,000 as calculated in fresh water, a liquid velocity of not less than 1 metre per second and the length of the supply pipe from the point of test fluid injection to add-on equipment should have a length not less than 20 times its diameter. A mixture inlet sampling point and a thermometer pocket should be provided near add-on equipment inlet and an outlet sampling point and observation window should be provided on the discharge pipe.

4.5 In order to approach isokinetic sampling – i.e. the sample enters the sampling pipe at stream velocity – the sampling arrangement should be as shown in figure 2 and, if a cock is fitted, free flow should be affected for at least one minute before any sample is taken. The sampling points should be in pipes running vertically.

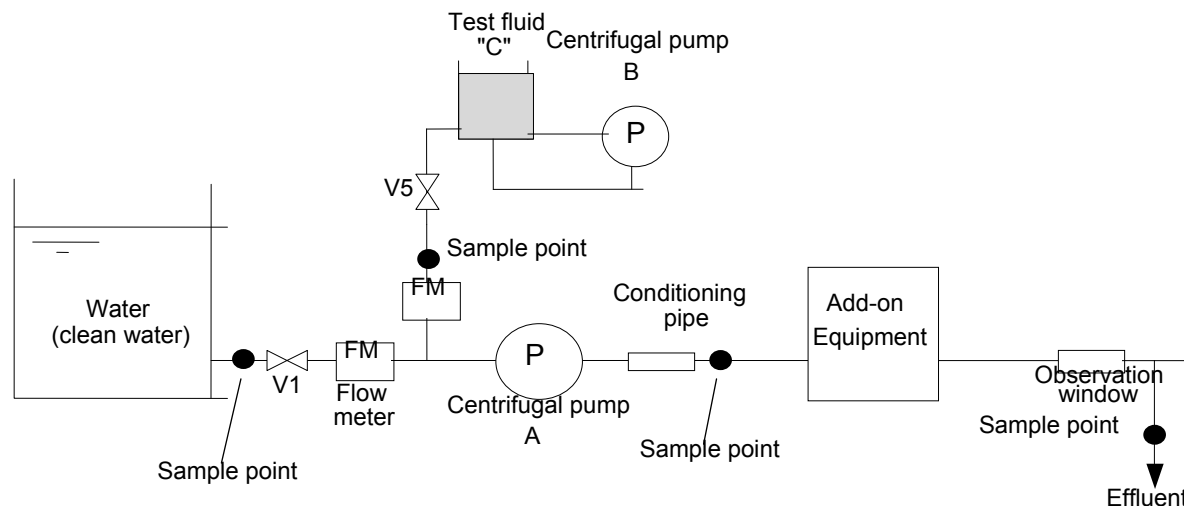

Figure 3 – Test rig

4.6 In the case of add-on equipment depending essentially on gravity, the feed to the add-on equipment of the test water and test fluid mixture should be maintained at a temperature not greater than 40°C, and heating and cooling coils should be provided where necessary. The water should have a density of not more than 1.015 at 20°C. In other forms of separation where the dependence of separation efficiency on temperature is not established, tests should be carried out over a range of influent temperatures representing the normal shipboard operating range of 10°C to 40°C or should be taken at a temperature in this range where the separation efficiency is known to be worst.

4.7 In those cases where, for add-on equipment, it is necessary to heat water up to a given temperature and to supply heat to maintain that temperature, the tests should be carried out at the given temperature.

4.8 The tests with test fluid "C" should be carried out as follows:

- .1 prior to the test with test fluid "C", add-on equipment should be filled up with water (density of not more than 1.015 at 20°C);
- .2 add-on equipment should be fed with a mixture composed of 6% test fluid "C" and 94% water to have emulsified oil content of 3,000 ppm in the test water until steady conditions have been established. Steady conditions are assumed to be the conditions established after pumping through add-on equipment a quantity of test fluid "C"/water mixture not less than twice the volume of add-on equipment; and
- .3 the test should then proceed for 2.5 h. Samples should be taken at the effluent outlet at 50 minutes and 100 minutes after conditioning. At the end of this test, an air cock should be opened on the suction side of the pump and, if necessary, the test fluid "C" and water valves should be slowly closed together, and a sample taken at the effluent discharge as the flow ceases (this point can be checked from the observation window).

4.9 Sampling should be carried out as shown in figure 2 so that the sample taken will suitably represent the fluid issuing from the effluent outlet of add-on equipment.

4.10 Samples should be taken in accordance with ISO 9377-2:2000. The sample is to be extracted on the same day of collection, and be sealed and labelled in the presence of a representative of the national authority and arrangements should be made for analysis as soon as possible and in any case within seven days, provided the samples are being kept between 2°C and 6°C at laboratories approved by the Administration.

4.11 The oil content of the samples should be determined in accordance with part 4 of the annex to resolution MEPC.107(49).

4.12 When accurate and reliable oil content meters are fitted at inlet and outlet of add-on equipment, one sample at inlet and outlet taken during each test will be considered sufficient if they verify, to within $\pm 10\%$, the meter readings noted at the same instant.

PART 3

DOCUMENTATION OF APPROVAL

5.1 Satisfactory compliance with all the test requirements enumerated in part 1 or 2 of this annex should be shown in the certificate of type approval issued by the Administration in the format specified in paragraph 5.2 below. An Administration may issue a certificate of type approval based on separate testing or on testing already carried out under supervision by another Administration.

5.2 A certificate of type approval should be in the format shown in the appendix to this annex. The Certificate should identify the type and model of the add-on equipment to which it applies and identify equipment assembly drawings, duly dated. Each drawing should bear the model specification numbers or equivalent identification details. The certificate should include the full performance test protocol on which it is based. If a certificate of type approval is issued by an Administration based on a certificate previously issued by another Administration, the certificate should identify the Administration which conducted the test on add-on equipment and a copy of the original test results should be attached to it.

BADGE
OR
CIPHER

Appendix 1
Certificate of type approval for add-on equipment

Name of Administration

This is to certify that the add-on equipment listed below has been examined and tested in accordance with the requirements of the specifications of the annex to the 2011 Guidelines contained in resolution MEPC.205(62). This certificate is valid only for add-on equipment referred to below.

Add-on equipment supplied by

.....
Under type and model designation
and incorporating:

- * Add-on equipment manufactured by
to specification/assembly drawing No date
- * Coalescer/Absorbent/Membrane/Filter manufactured by
to specification/assembly drawing No
- * Control equipment manufactured by
to specification/assembly drawing No date
- * Other means
to specification/assembly drawing No

* For installation on oil filtering equipment supplied by

.....
Under type and model designation

Maximum throughput of system m³/h ____

Limiting conditions imposed

Test date and results attached in the appendix.

Official stamp

Signed
Administration of
Date this day of 20

* Delete as appropriate.

Appendix 2

Test data and results of tests conducted on add-on equipment in accordance with Part 1 or 2 of the annex to the 2011 Guidelines contained in resolution MEPC.205(62)

Add-on equipment submitted by

.....

Test location

.....

Method of sample analysis

.....

.....

.....

Samples analysed by

.....

Environmental testing of the electrical and electronic sections of the add-on equipment has been carried out in accordance with part 3 of the annex to the 2011 Guidelines contained in resolution MEPC.205(62). The equipment functioned satisfactorily on completion of each test specified on the environmental test protocol.

.....

.....

.....

Test fluid .C.

Surfactant – documentary evidence*

Iron oxides – documentary evidence*

Test water

Density at 20°C

Solid matter present

Test temperatures

Ambient °C

Test fluid .C. °C

Test water °C

Diagram of test rig attached

Diagram of sampling arrangement attached

* Certificate or laboratory analysis.

TEST RESULTS (IN PPM) AND TEST PROCEDURES

Test fluid C

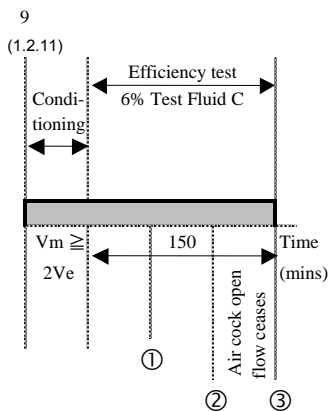

	1	2	3
Influent			
Effluent			

Signed Date Official stamp

(Official stamp or equivalent identification and the date of approval to be placed on all pages of the test protocol.)

RESOLUTION MEPC.205(62)

Adopted on 15 July 2011

2011 GUIDELINES AND SPECIFICATIONS FOR ADD-ON EQUIPMENT FOR UPGRADING RESOLUTION
MEPC.60(33)-COMPLIANT OIL FILTERING EQUIPMENT